

Specification:

The Irinox **Model LCRA 202.120 Blast Chiller** shall have the following characteristics: Capacity – (1) single-rack roll-in unit or (1) standard oven trolley (see interior dimensions below); four standard chilling modes, including LOGIK Chill® product/program memory; Chefs Data Vision® HACCP data management software; remote condensing unit; and core product temperature probe standard, plus all the features listed, and the options or accessories checked.

Sizing & Unit Production Guide:	LCRA
Blast Chilling Capacity [194 to 37° F]*	250 lbs.

* Per production cycle

Standard Construction Features:

- All Type 304 stainless steel construction
- CFC-free high density polyurethane insulation
- Easy-open, hinged-right, door with replaceable magnetic gasket
- Ergonomic product core temperature probe with insulated cable
- Remote compressor/condenser package standard for mounting within 75 feet of unit.
- Approved R404A refrigerant used in system
- Inside access door for evaporator cleaning & maintenance
- Water & smudge-resistant touch pad controls
- Flush-mounted, stainless steel floor
- Interior dimensions: 72" H x 30¾" W x 33¾" D

Product Warranty Protection:

- 1 year, parts & labor
- 5-years on compressor (if provided)

Unique Performance Features:

- Indirect air flow-ventilation reduces product moisture loss
- Chilling compartment has coved corners for uniform air movement and easier cleaning
- Special fan design speeds product chilling
- LOGIK chill® automatically determines fastest and gentlest chilling parameters
- Data Management Software standard for HACCP reporting
- Recipes Menu for storage of customized chilling cycles
- Choice of four product chilling modes including:

Operating Mode Performance & Applications:

Operating Modes:	Temperature Δ [F]*	Time	Minimum Air Temp. Used [F]	Product Applications
LOGIK chill®	194° to 37°	90 minutes	Variable	Suitable for any product
Soft Chill	194° to 37°	90 minutes	32°	Delicate or thin food items
Hard Chill	194° to 37°	90 minutes	Variable to -4°	Dense, large food items
Hard Chill Plus	194° to 37°	90 minutes	-20°	Difficult to chill products

* Core product temperature



Item No.	_____
Qty.	_____
Project	_____

**Roll-In Blast Chiller
Model: LCRA 202.120**

Standard LC Series Controls:

- Power ON-OFF
- Four Operating Mode Selections
- LOGIK chill® program storage & recall
- Chilling cycle START-STOP
- Chill-by-time or to core temperature
- Compartment Air & Core Temperature continuous LCD displays
- Large Functions & User Guide LCD Display
- UV light controls [Optional]
- HACCP printout [Optional]
- Large knob to change settings

Options & Accessories [Please Check]:

- Rolling rack: Capacity [12]18"x 26" x 1" pans or [24] 12"x 20" x 2 ½" pans
- 3 core probes module [one core probe std.]
- Sous vide pouch core temperature probe
- Probe holder for liquids [centers probe in pan or container]
- Connection Kit for remote condenser unit
- Door hinged left, opens left [Hinged right std.]
- Built-in time/temperature recorder/printer
- Portable HACCP Data Printer
- Locking control panel [for Corrections use]
- UV Sterilizing lamps
- Single flexible core probe (for Corrections use)
- PC Connection Kit

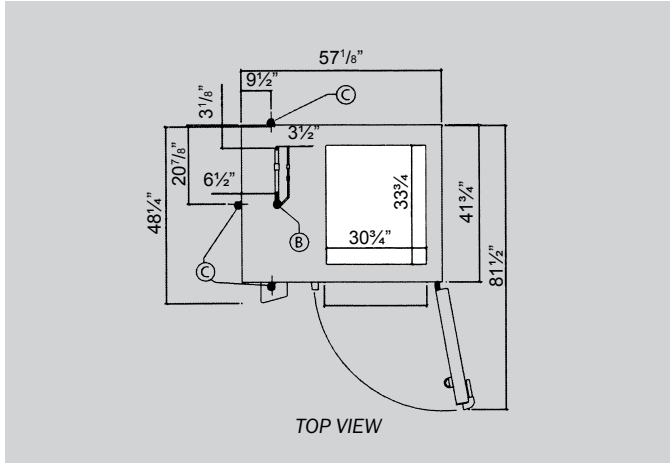

Unit Dimension - Floor Level

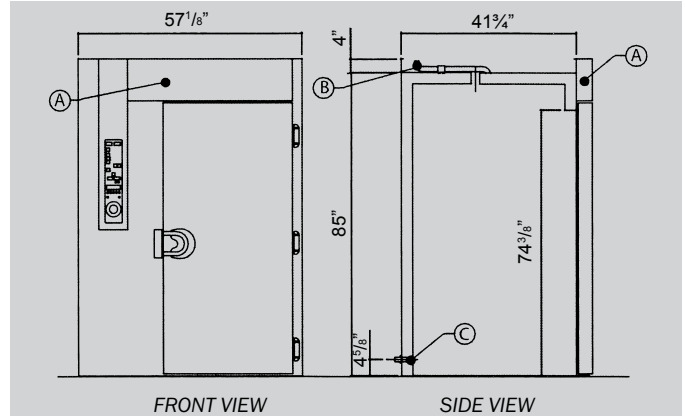

□ : Max available space

- A: Electrical cable junction box
- B: Refrigerant pipes line
- C: Drainage discharge Ø 1 1/2"
- D: Water discharge

Chiller Dimensions & Weight		
LCRA 202.120	Unit/Tare	Crated**
Width	57 1/8"	97 1/2"
Depth	48 1/4"	52 1/2"
Height - floor level	89"	62"
Weight	904 lbs.	1320 lbs.

[E] Chiller Electric Data/Power Requirements			
Voltage/Phase	LCRA 202.120		
	KW	HP	[AMPS]
208 Volt - 3-Phase	1.7	2.3	5.7

[D] Drain Connection: 1 1/2" ID [Per local codes].

** Unit ships lying down



Continued product development may necessitate specification changes without notice.

Model: 605 Remote Condenser Unit Dimensions

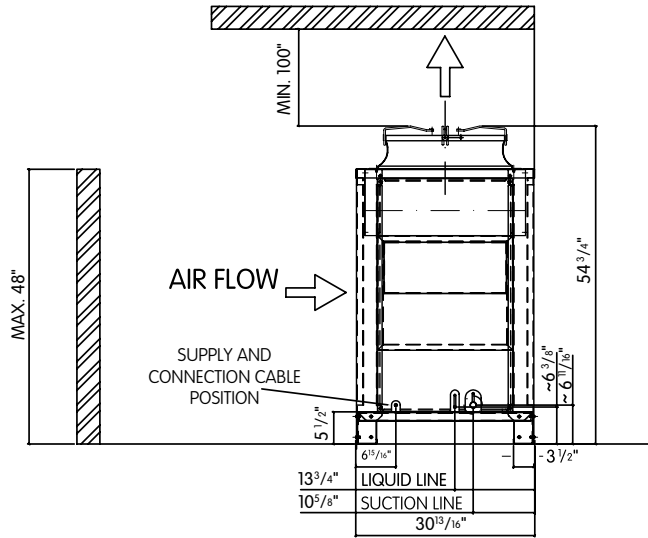

Remote Condenser Typical Installation & Minimum Clearances

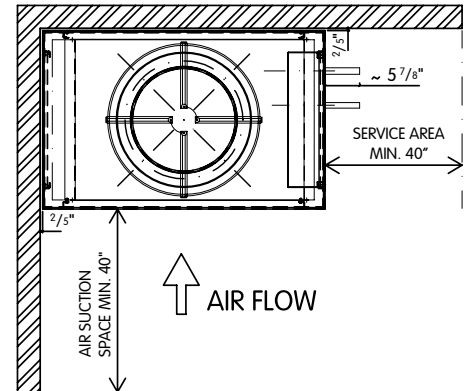
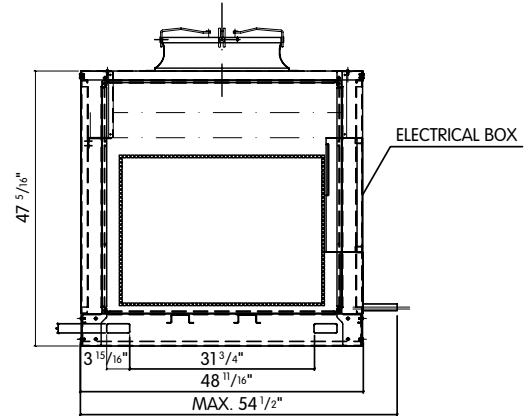

Remote Condenser Dimensions & Weight

Condenser:	Unit	Crated
For Chiller	605	605
Width	48 ¹¹ / ₁₆ "	60 ¹ / ₄ "
Depth	30 ⁹ / ₁₆ "	34 ¹ / ₄ "
Height	54 ³ / ₄ "	66 ¹⁵ / ₁₆ "
Weight	595 lbs.	695 lbs.

Condenser Unit Electric Data/Requirements

Model	605
Voltage/Phase/Hz	208/3/60
Total KW	9.7
Total HP	13
AMPS	33

Key Remote Refrigeration System Data & Connections

Model:	605
Compressor Rating	6 HP
Refrigeration Yield*	14.63 kw - 49,965 BTU/hour
Remote Condenser	Standard
Refrigerant Type	R404A
Discharge Connection	1/2"
Suction Connection	1 1/8"
Start Current (Locked Rotor)	163 A
Displacement	967 ft ³ /hour

*Sized to a 14 °F suction line, 104 °F liquid line

Water-Cooled Condenser Requirements

Model:	605
Water Inlet Connection	3/4"
Water Outlet Connection	3/4"
Minimum Water Pressure	7.25 PSI
Water Consumption	433 gal./hr.

For dimensions of water cooled unit, please contact us.

Installation Notes:

1. Installation and charging of refrigeration lines are the responsibility of owner/installation contractor.
2. 5 wires #14AWG must be installed by owner/installation contractor between the cabinet and the condensing unit. The connection should be performed according to the electrical diagram.
3. If installed outdoors, Condenser Unit should be protected from direct sunlight and provided with a minimum of 24" air space.
4. If installed indoors, condenser unit may require water-cooling. [See table above.]
5. If installed over 75' from chiller, installer must contact IRINOX USA for proper refrigerant pipe sizing.

Roll-In Blast Chiller
Model: LCRA 202.120

IRINOX Blast Chilling Systems:

The Irinox blast chiller can be teamed up with roll-in ovens, holding cabinets and walk-in refrigeration to provide a complete cook-chill food production system. The use of transport carts for pan loading, staging, unloading and storage reduces multiple handling of pans and allows a few employees to produce thousand of portions or meals per day. Use of Irinox blast chillers can reduce per-portion food costs, improve both food quality and variety, and enhance food safety.

IRINOX SOLUTIONS

FLOOR LEVEL

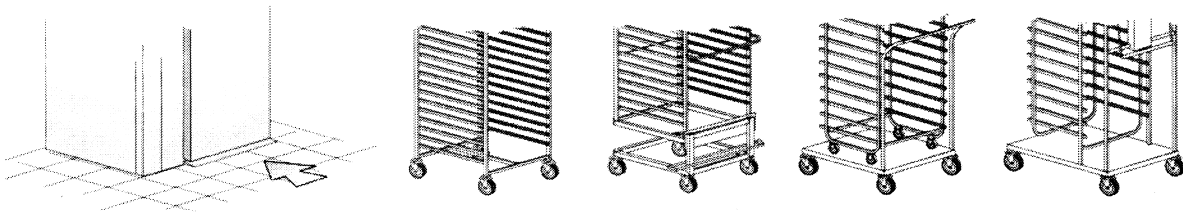

Continued product development may necessitate specification changes without notice.