

HCMA 202.100

Specification:

The Irinox **Model HCMA 202.100 Blast Chiller** shall have the following characteristics: Capacity – (1) single-rack roll-in unit or (1) standard oven trolley (see interior dimensions below); three standard chilling modes, remote condensing unit; and core product temperature probe standard, plus all the features listed, and the options or accessories checked.

Sizing & Unit Production Guide:	HCMA
Blast Chilling Capacity [194 to 37° F]*	220 lbs.
Shock Freezing Capacity [to 0° F]	125 lbs.

* Per production cycle



Item No.	_____
Qty.	_____
Project	_____

Standard Construction Features:

- All Type 304 stainless steel construction
- CFC-free high density polyurethane insulation
- Easy-open, hinged-right, door with replaceable magnetic gasket
- Ergonomic product core temperature probe with insulated cable
- Remote compressor/condenser package standard for mounting within 75 feet of unit.
- Approved R404A refrigerant used in system
- Inside access door for evaporator cleaning & maintenance
- Water & smudge-resistant touch pad controls
- Flush-mounted, stainless steel floor
- Interior dimensions: 72" H x 30¾" W x 33¼" D

Product Warranty Protection:

- 1 year, parts & labor
- 5-years on compressor (if provided)

Unique Performance Features:

- Indirect air flow-ventilation reduces product moisture loss
- Chilling compartment has coved corners for uniform air movement and easier cleaning
- Special fan design speeds product chilling
- Heated Product Core temperature control
- Choice of three product chilling modes including:

**Roll-In Blast Chiller
Model: HCMA 202.100**

Standard HC Series Controls:

- Power ON-OFF
- Three Operating Mode Selections
- Chilling cycle START-STOP
- Chill-by-time or to core temperature
- Compartment Air & Core Temperature continuous LCD displays
- UV light controls [Optional]
- HACCP printout [Optional]

Options & Accessories [Please Check]:

- Rolling rack: Capacity [12]18"x 26" x 1" pans or [24] 12"x 20" x 2 ½" pans
- Sous vide pouch core temperature probe
- Probe holder for liquids [centers probe in pan or container]
- Connection Kit for remote condenser unit
- Door hinged left, opens left [Hinged right std.]
- Built-in time/temperature recorder/printer
- Portable HACCP Data Printer
- Locking control panel [for Corrections use]
- UV Sterilizing lamps
- Data Management Software & Data Port for HACCP Reporting
- PC Connection Kit

Operating Mode Performance & Applications:

Operating Modes:	Temperature Δ [F]*	Time	Minimum Air Temp. Used [F]	Product Applications
Soft Chill	194° to 37°	90 minutes	32°	Delicate or thin food items
Hard Chill	194° to 37°	90 minutes	Variable to -4°	Dense, large food items
Shock Freeze	to 0°	4 hours	-31° to -40°	All cooked and raw products

* Core product temperature



IRINOX USA 50 Oliver Street, Suite W1, North Easton, MA 02356
508-230-5818 Fax: 508-230-5819 www.irinox.com

HCMA 202.100

Unit Dimension - With External Ramp

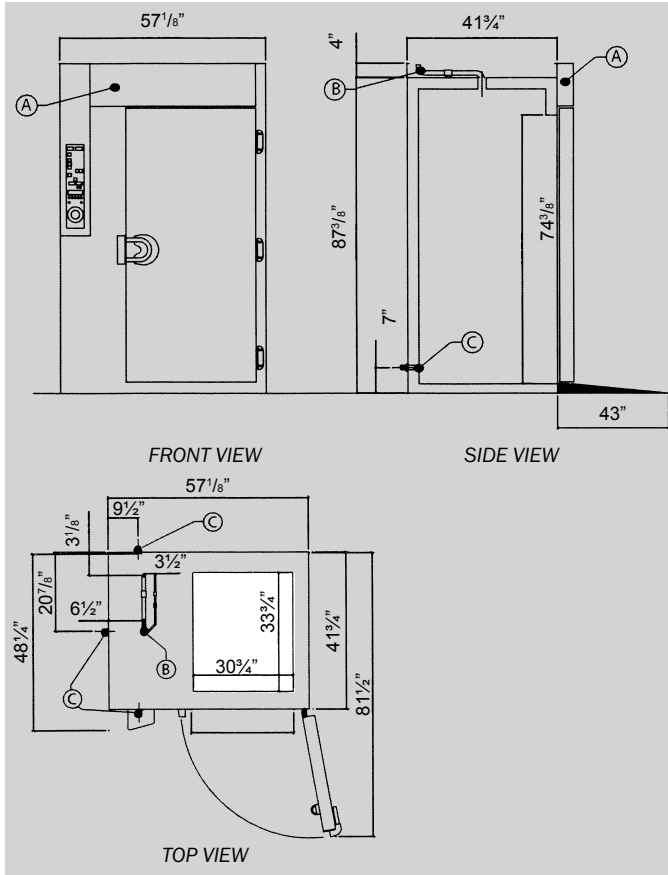

Unit Dimension - With Sunken Floor

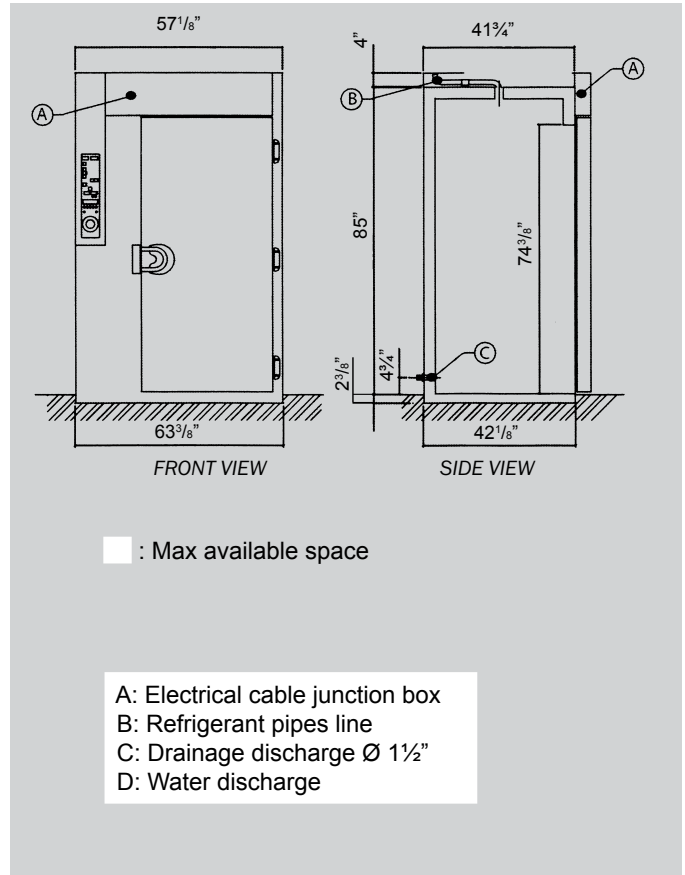

Chiller Dimensions & Weight

HCMA 202.100	Unit/Tare	Crated**
Width	57 1/8"	97 1/2"
Depth	48 1/4"	52 1/2"
Height w/Ramp	91 3/4"	66"
Height w/Sunken Floor	89"	62"
Weight	904 lbs.	1320 lbs.

[E] Chiller Electric Data/Power Requirements

Voltage/Phase	HCMA 202.100		
	KW	HP	[AMPS]
208 Volt - 3-Phase	1.7	2.3	5.7

[D] Drain Connection: 1 1/2" ID [Per local codes].

** Unit ships lying down



Continued product development may necessitate specification changes without notice.



IRINOX USA 50 Oliver Street, Suite W1, North Easton, MA 02356
 508-230-5818 Fax: 508-230-5819 www.irinox.com

HCMA 202.100

Model: 605 Remote Condenser Unit Dimensions

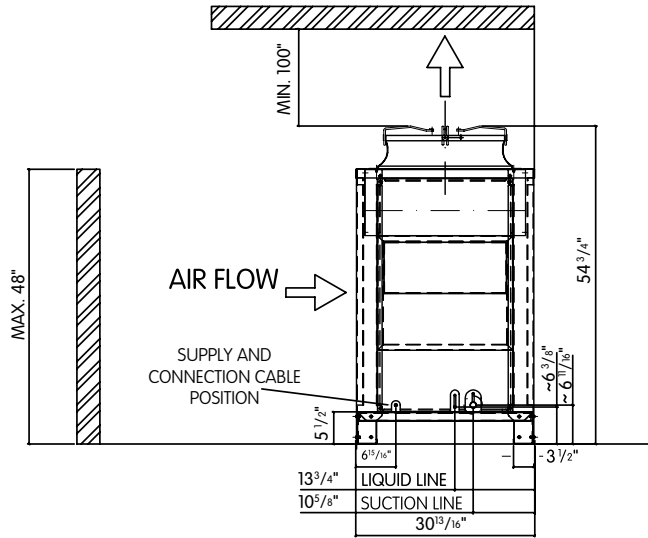

Remote Condenser Typical Installation & Minimum Clearances

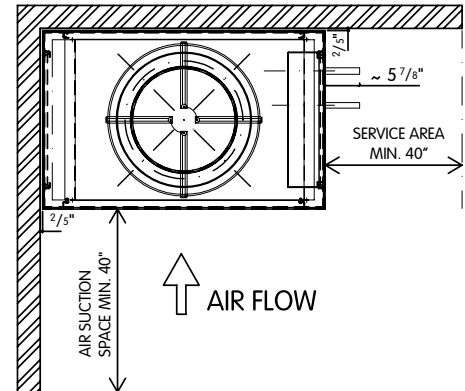
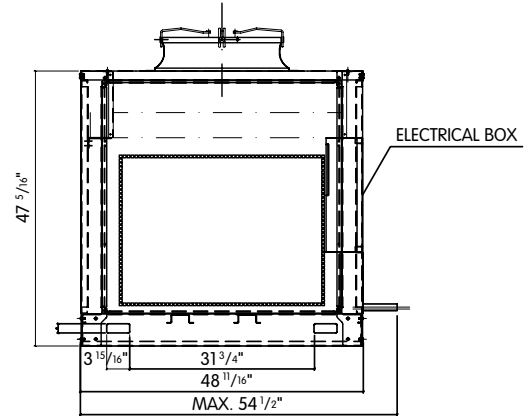

Remote Condenser Dimensions & Weight

Condenser:	Unit	Crated
For Chiller	605	605
Width	48 ¹¹ / ₁₆ "	60 ¹ / ₄ "
Depth	30 ⁹ / ₁₆ "	34 ¹ / ₄ "
Height	54 ³ / ₄ "	66 ¹⁵ / ₁₆ "
Weight	595 lbs.	695 lbs.

Condenser Unit Electric Data/Requirements

Model	605
Voltage/Phase/Hz	208/3/60
Total KW	9.7
Total HP	13
AMPS	33

Key Remote Refrigeration System Data & Connections

Model:	605
Compressor Rating	6 HP
Refrigeration Yield*	14.63 kw - 49,965 BTU/hour
Remote Condenser	Standard
Refrigerant Type	R404A
Discharge Connection	1/2"
Suction Connection	1 1/8"
Start Current (Locked Rotor)	163 A
Displacement	967 ft ³ /hour

*Sized to a 14 °F suction line, 104 °F liquid line

Water-Cooled Condenser Requirements

Model:	605
Water Inlet Connection	3/4"
Water Outlet Connection	3/4"
Minimum Water Pressure	7.25 PSI
Water Consumption	433 gal./hr.

For dimensions of water cooled unit, please contact us.

Installation Notes:

1. Installation and charging of refrigeration lines are the responsibility of owner/installation contractor.
2. 5 wires #14AWG must be installed by owner/installation contractor between the cabinet and the condensing unit. The connection should be performed according to the electrical diagram.
3. If installed outdoors, Condenser Unit should be protected from direct sunlight and provided with a minimum of 24" air space.
4. If installed indoors, condenser unit may require water-cooling. [See table above.]
5. If installed over 75' from chiller, installer must contact IRINOX USA for proper refrigerant pipe sizing.

IRINOX®

IRINOX USA 50 Oliver Street, Suite W1, North Easton, MA 02356
508-230-5818 Fax: 508-230-5819 www.irinox.com

Roll-In Blast Chiller Model: HCMA 202.100

IRINOX Blast Chilling Systems:

The Irinox blast chiller can be teamed up with roll-in ovens, holding cabinets and walk-in refrigeration to provide a complete cook-chill food production system. The use of transport carts for pan loading, staging, unloading and storage reduces multiple handling of pans and allows a few employees to produce thousand of portions or meals per day. Use of Irinox blast chillers can reduce per-portion food costs, improve both food quality and variety, and enhance food safety.

IRINOX SOLUTIONS

WITH EXTERNAL FIXED RAMP

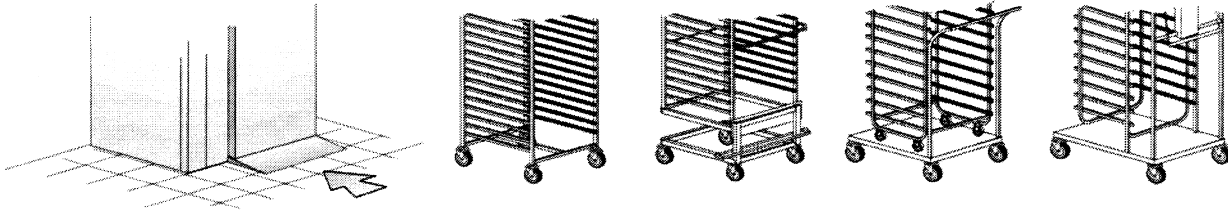

WITH SUNKEN FLOOR

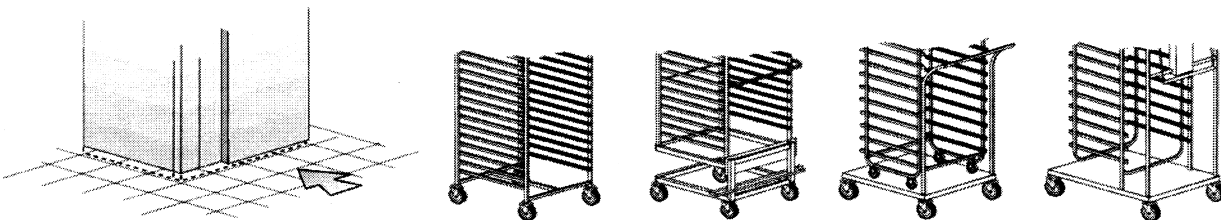

Continued product development may necessitate specification changes without notice.

IRINOX®

IRINOX USA 50 Oliver Street, Suite W1, North Easton, MA 02356
508-230-5818 Fax: 508-230-5819 www.irinox.com